



SPEEDO CORRECTOR INSTALLATION INSTRUCTIONS

IMPORTANT NOTES

To fit this unit you will need a basic knowledge of vehicle wiring and auto electrical tools.
To ensure that your installation is trouble free, please read all of the following instructions carefully and completely before commencing work.

WARNING

Warranty does not include failure to properly install the Speedo Corrector. Consideration of a warranty claim is at the sole discretion of ChipTorque.

OTHER NOTES

If you have any problems or questions please contact ChipTorque on (07) 5596 4204.
Some vehicle speed sensor inputs do not feed directly to the speedometer. For example, some are sent to the ECU. The ECU then sends out another circuit to the speedometer. In such cases, fit the speedo corrector into the circuit between the ECU and speedometer.
All connections should be made using either quality crimp terminals or soldered and insulated.

FITTING

1. Locate the speedo signal wire.
2. Cut the speedo wire at an accessible location.
3. Connect white (signal in) wire of speedo corrector to original speedo circuit from vehicle speed sensor.
4. Connect blue (signal out) wire of speedo corrector to original speedo circuit that goes to the speedometer.
5. Locate a suitable 12v fused ignition feed near the speedo corrector and securely attach red wire.
6. Locate a suitable earth near the speedo corrector and securely attach the black wire.

SETTING

Run the vehicle on a dyno at various speeds and use the dials on the speedo corrector to calibrate speed to the speed indicated on the dyno.

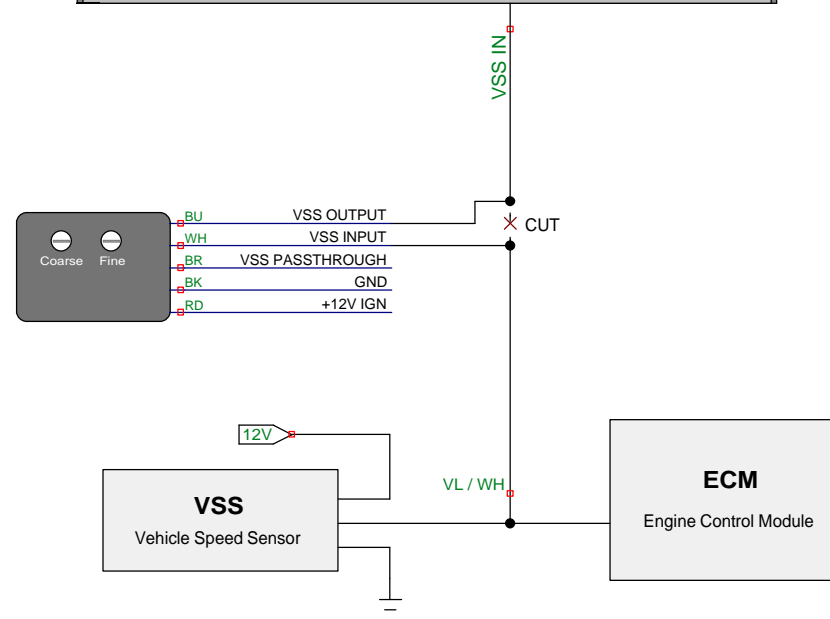
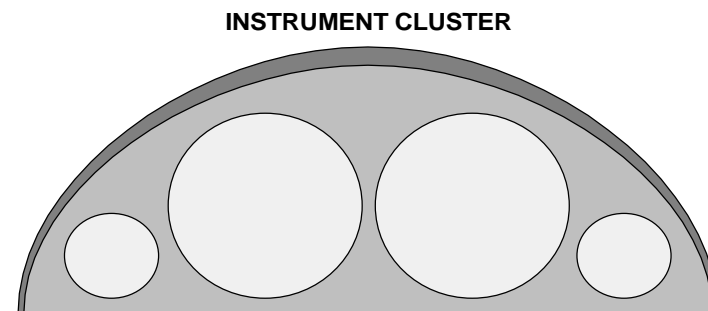

Title Speedo Corrector (HOLDEN VN/VP AT/T5 & VR/VS T5)		
Author SMH ChipTorque		
File IIPTORQUE\Desktop\XWD\Speedo Corrector.dsn	Document WD	
Revision 1.0	Date 3/10/2017	Sheets 2