

ECU TERMINALS - VIEW FROM BACK OF CONNECTORS (WIRE)

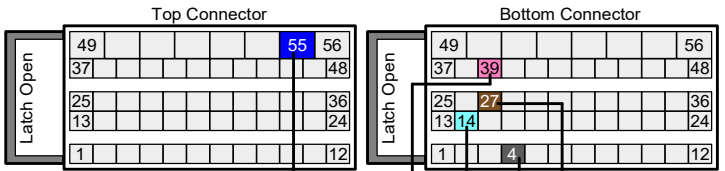

Harness Plug (Grey)
Connector 'A'

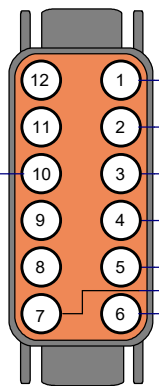
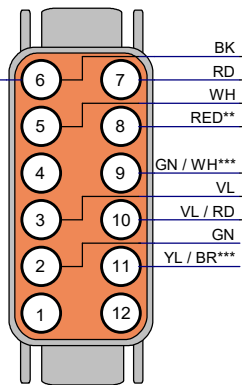

Use eye terminal to connect to chassis ground.

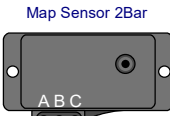
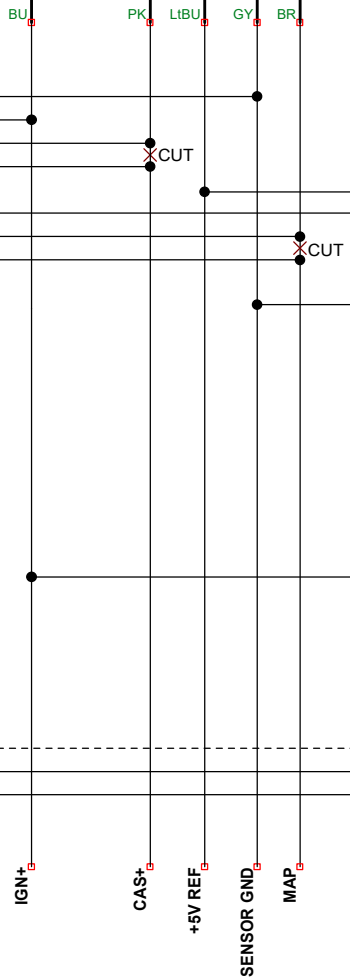

Map Sensor 2Bar
Into / under connector. Pin "C" is closest to the Vacuum / Boost nipple.

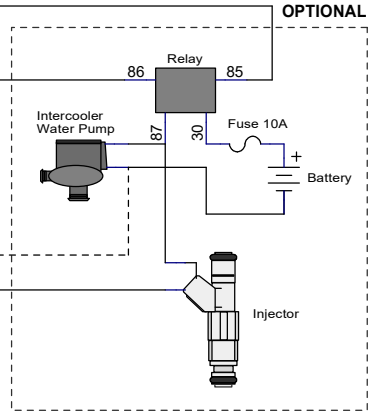

XEDE PROCESSOR WIRING DIAGRAM

* One or both chassis grounds must be connected if any of the following XEDE features are to be used: Water spray, boost control, auxiliary injector drive.
 ** Red wire in 3 core shielded cable.
 *** Wire colour may have changed due to manufacturing shortages. Wire trace colour can change subject to availability. Function remains the same.

DO NOT terminate the shield wire in the 3 core cable.
 On some versions of the harness there is 2 black wires, DO NOT use the black wire from the shielded cable unless specifically instructed.

Title Suzuki Jimny JB74 K15B		
Author SMH ChipTorque		
File .CHIPTORQUE\Desktop\XWD\S Jimny K15B.dsn	Document XWD	
Revision 1.0	Date 15/10/2019	Sheets 1