

ECU TERMINALS - VIEW FROM BACK OF CONNECTORS (WIRE VIEW)

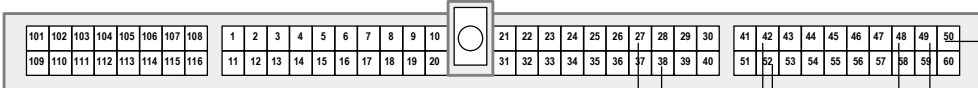

Harness Plug (Grey)
Connector 'A'

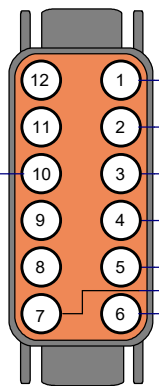
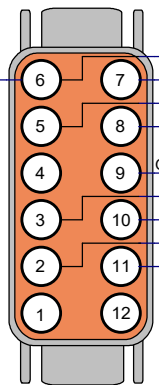

Use eye terminal
to connect to
chassis ground.

Into / under connector.
Pin "C" is closest to the
Vacuum / Boost nipple.

Map Sensor 2Bar

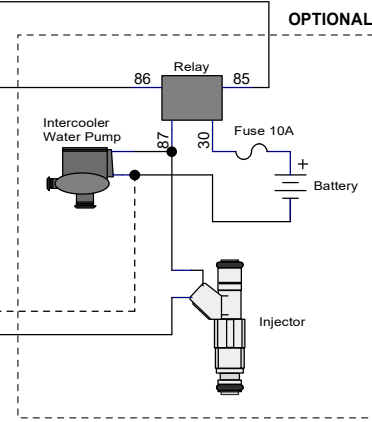
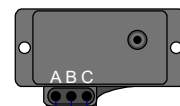

Optional Dual Map Select

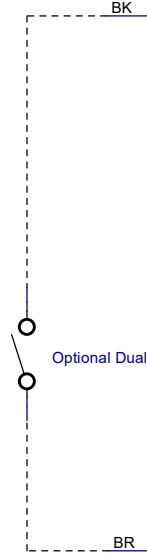

XEDE PROCESSOR WIRING DIAGRAM

- * One or both chassis grounds must be connected if any of the following XEDE features are to be used: Water spray, boost control, auxiliary injector drive.
- ** Red wire in 3 core shielded cable.
- *** Wire colour may have changed due to manufacturing shortages. Wire trace colour can change subject to availability. Function remains the same.

DO NOT terminate the shield wire in the 3 core cable.
On some versions of the harness there is 2 black wires, DO NOT use the black wire from the shielded cable unless specifically instructed.

| | | |
|---|--------------------|-----------------|
| Title Nissan Patrol TB45 | | Document XWD |
| Author SMH ChipTorque | | |
| File :CHIPTORQUE\Desktop\XWD\N Patrol TB45.dsn | | Sheets 1 |
| Revision 1.0 | Date 25/01/2017 | |